TECHNICAL DRAWING APPLICATIONS

(Three hours)

*Answers to this paper must be written **neatly** on the paper provided separately.*

*You will **not** be allowed to draw/write during the first 15 minutes.*

This time is to be spent in reading the question paper.

The time given at the head of the paper is the time allowed for writing the answers.

*Attempt **five** questions in all.*

*You must attempt **three** questions from **Section A** and **two** questions from **Section B***

Each section should be answered on a separate paper.

All questions must be answered in full scale.

All construction lines must be shown.

All dimensions are in millimeters unless specified otherwise.

The intended marks for question or parts of questions are given in brackets [].

SECTION A (48 Marks)

*Answer any **three** questions from this section.*

Question 1.

In a diagram a line measuring 12 mm was marked as 4 cm. Calculate the R.F. [16]

Using the same R.F. construct a DIAGONAL SCALE long enough to measure 3.61 dm.

Taking the measurement from the scale constructed, draw an equilateral triangle of side 3.61 dm.

Draw the incircle of this triangle.

Show the data and the working neatly.

This paper consists of 8 printed pages.

Question 2.

Construct an ELLIPSE by the OBLONG METHOD.

[16]

Given : Major Axis = 150 mm

Minor Axis = 100 mm.

Question 3.

(a) Draw a square of side 100 mm. Construct four equal circles inside the square so that each circle touches one side of the square and two other equal circles externally. [6]

(b) Refer to **Figure 1** given below. It shows the Front View (F.V.) and the Top View (T.V.) of a right circular cylinder in the **FIRST ANGLE METHOD** of projection. Its axis is perpendicular to the horizontal plane and parallel to the vertical plane. Copy the given figure and draw its AUXILIARY TOP VIEW. [10]

The auxiliary plane X_1Y_1 is shown in the figure.

Given: Diameter of the base = 70 mm

Length of axis = 75 mm.

ClassResult.in

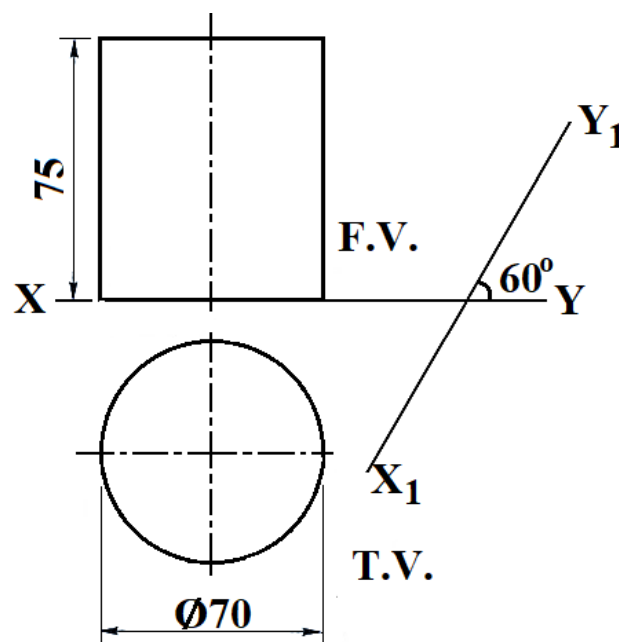

Figure 1

Question 4.

Refer to **Figure 2** given below. It shows the Front View (F.V.) and the Top View (T.V.) of an object in the **FIRST ANGLE METHOD** of projection. Draw the **OBLIQUE VIEW** when the receding axis is inclined at 45° to the horizontal. [16]

(Do not insert any dimensions.)

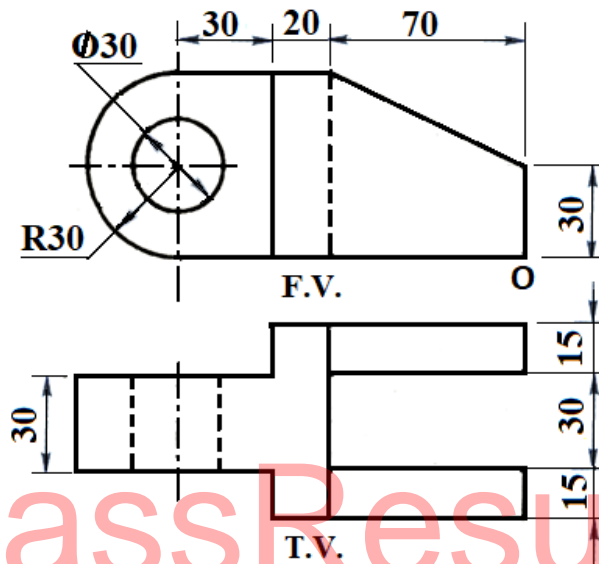

Figure 2

Question 5.

Refer to **Figure 3** given below. Copy the given template.

[16]

(Insert any 4 dimensions.)

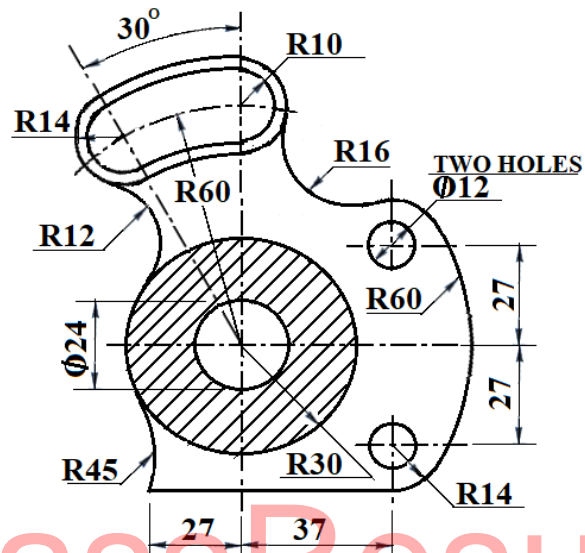

Figure 3

SECTION B (52 Marks)

Answer any **two** questions from this Section.

Question 6.

- (a) Refer to **Figure 4** given below. It shows the Front View (F.V.) and the Top View (T.V.) of a right hexagonal prism in the **THIRD ANGLE METHOD** of projection. [12]

Its axis is perpendicular to the horizontal plane (H.P.) and parallel to the vertical plane (V.P.). Two sides of its base are perpendicular to the V.P. The prism is cut by a cutting plane inclined at 60° to the H.P. and perpendicular to the V.P. The Vertical Trace (V.T.) of the cutting plane is shown in the figure.

Draw the:

- (i) Front View
- (ii) Sectional Top View
- (iii) Development of the Lateral Surface of the remaining **part P** of the Prism.

Given: Side of the base = 30 mm

Length of Axis = 70 mm.

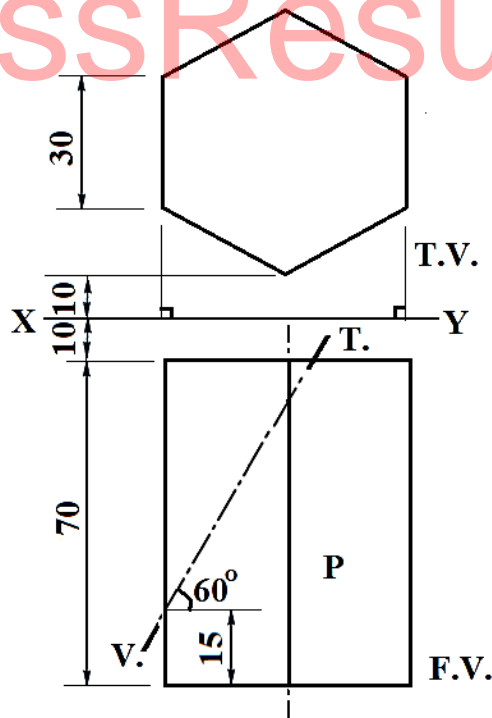

Figure 4

- (b) Refer to **Figure 5** given below. It shows the Front View (F.V.) and the Top View (T.V.) of a right square pyramid in the **THIRD ANGLE METHOD** of projection. [14]

Its axis is perpendicular to the horizontal plane (H.P.) and parallel to the vertical plane (V.P.). The pyramid is cut by a cutting plane inclined at 30° to the H.P. and perpendicular to the V.P. The Vertical Trace (V.T.) of the cutting plane is shown in the figure. Draw the:

- (i) Front View
- (ii) Sectional Top View
- (iii) Sectional Left Hand Side View

Given: Side of the base = 40 mm

Length of Axis = 75 mm.

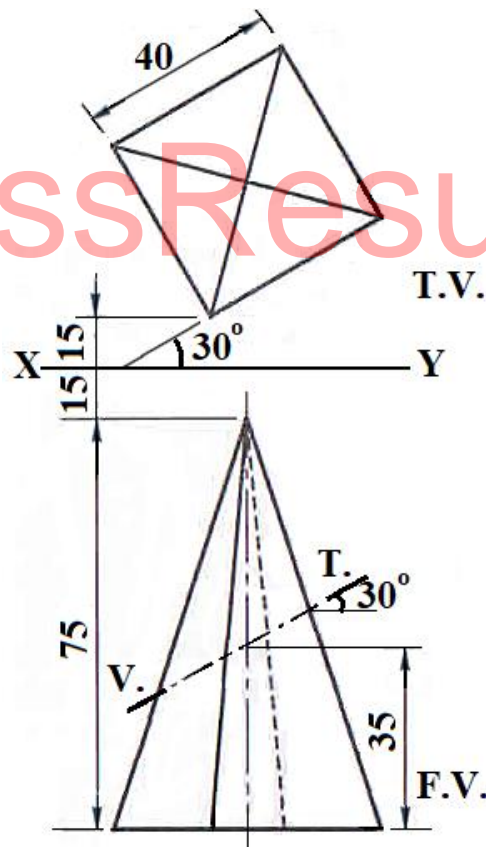

Figure 5

Question 7.

Refer to **Figure 6** given below.

[26]

Copy the given ISOMETRIC VIEW.

(Do not insert any dimensions.)

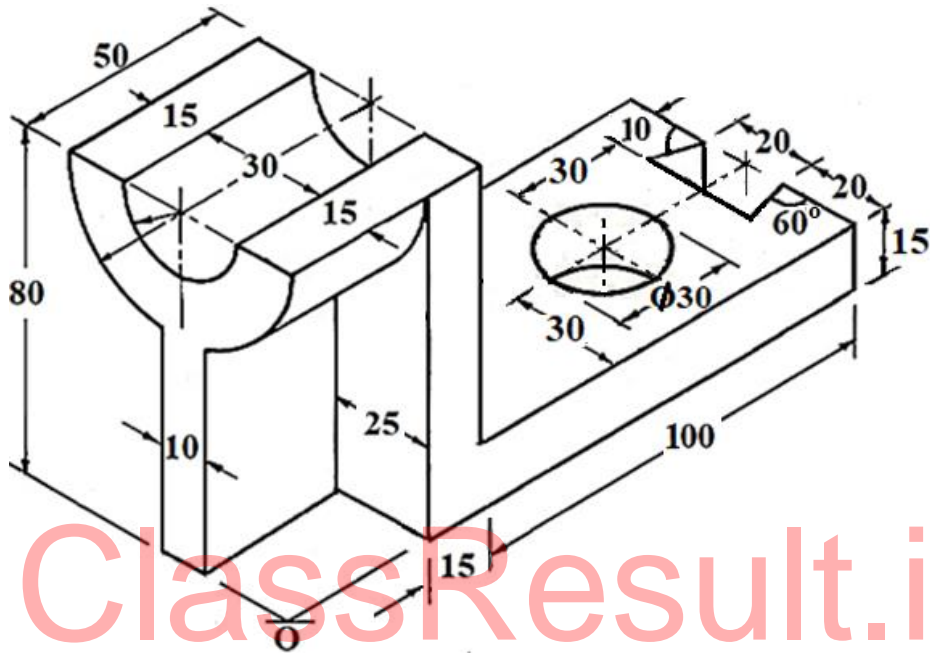

Figure 6

Question 8.

Refer to **Figure 7** given below. Using the **FIRST ANGLE METHOD** of projection, [26]
draw the:

- (i) Full Sectional Front View [section along A - A]
- (ii) Top View
- (iii) Left Hand Side View.

(Insert any 6 dimensions.)

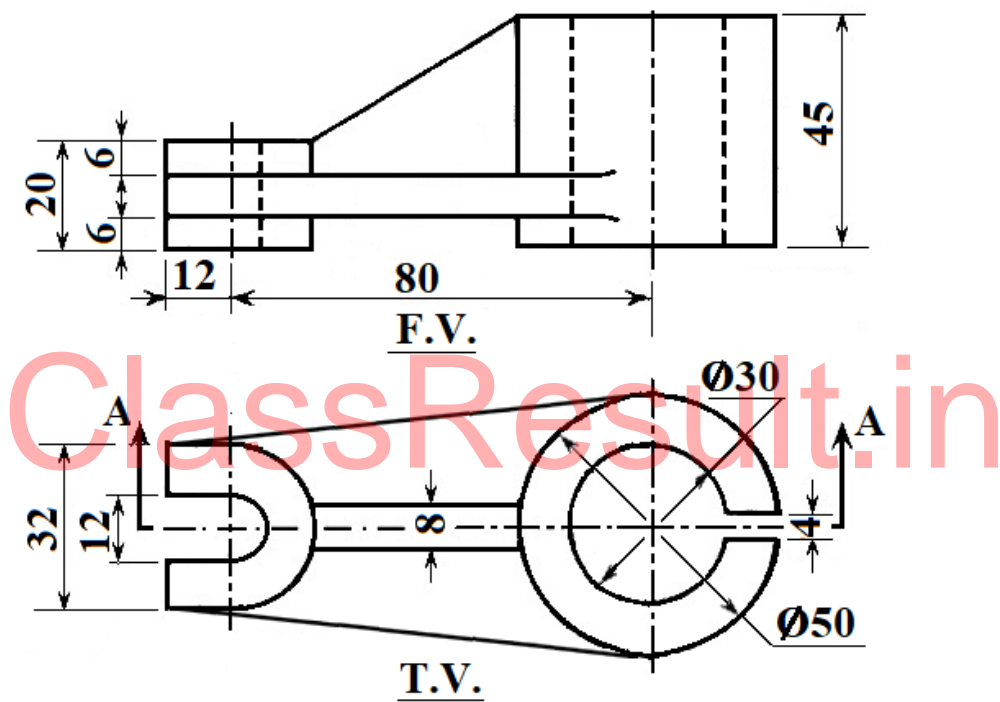

Figure 7